



LABORATORY MIXERS

Model L5M-A

Capacity

1ml up to 12 liters.

Motor Unit

Robust two-piece designed for cool, quiet and continuous operation.

Motor

1hp (750W) 110 volt, single phase (220 volt optional), 60 Hz. Nominal maximum speed 10,000 rpm.

Speed Control

Infinitely variable electronic speed control with integral on/off switch.

Electric Rise & Fall Bench Stand

The mixing unit may be effortlessly raised and lowered using the push-button control on the motor unit.

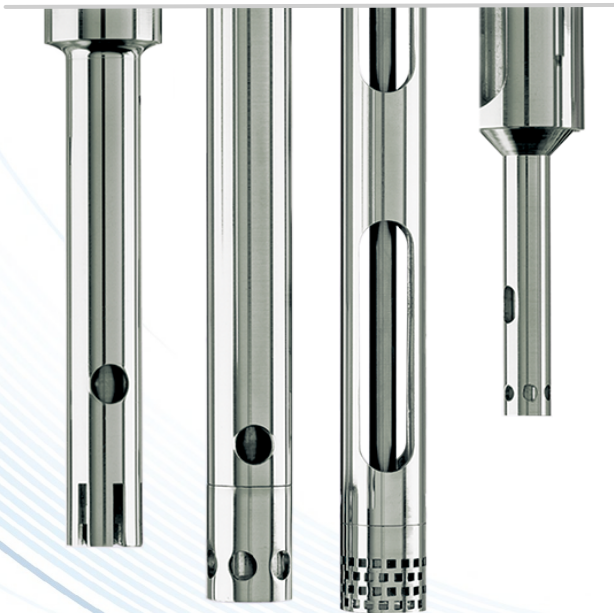

Construction

All wetted parts are in grade 316 stainless steel with the exception of the bush, which may be bronze alloy or PTFE. L5 Series mixers are finished in a tough, easy-to-clean white engineered polymer.

The flat base is covered by a removable non-slip mat, which is resistant to most solvents.

Assemblies

Over 40 interchangeable mixing assemblies are available including In-Line, Ultramix, Duplex and Tubular assemblies.



Controls & Instrumentation

	L5M-A	Sealed Unit	L2 Air	AX60	AX5	AX Air
Touch Pad Control	●	●			●	
Tachometer	●	●			●	
Programmable Timer	●	●			●	
Ammeter	●	●			●	
DataLogger	○	○			○	

Materials

Wetted Parts: 316L Stainless	●	●	●	●	●	●
Body: Nylon Coated Stainless	●	●			●	
Body: Stainless Steel	○	○	○	○	○	○

Motor

Power	1 hp (0.75kW)	1 hp (0.75kW)	0.25 hp (0.18kW)	Various Motors	1 hp (0.75kW)	0.5hp (0.375kW)
Single Phase	●	●			●	
3 Phase				●		
Variable Speed	●	●	●	○	●	●
Nominal Maximum Speed RPM	10,000	8,000	6,000	up to 6,000	6,000	3,600

Stand

Electric Rise & Fall	●	●		○	●	
Manual Stand			●	○		●

● Standard ○ Optional



LABORATORY MIXERS

Mixer Dimensions

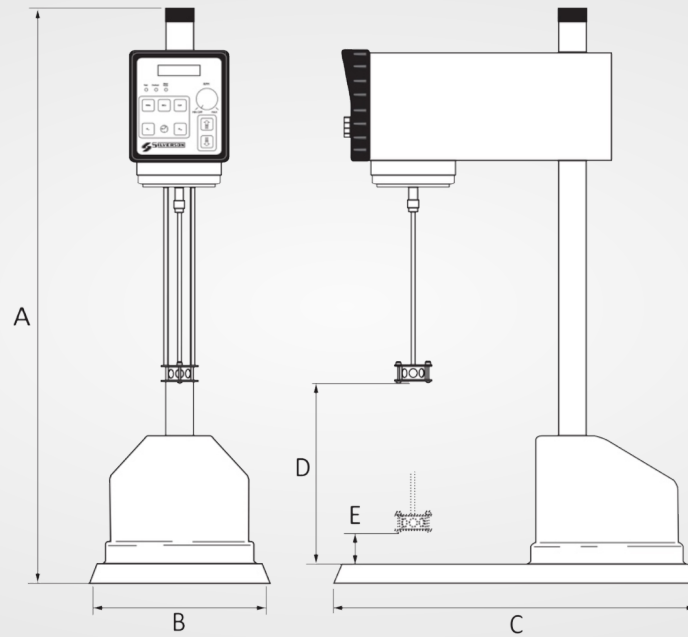

Model	A	B	C	D Max. Height	E Min. Height
L5M-A	37 ³ / ₄	12 ¹ / ₄	20 ⁷ / ₈	12 ³ / ₄	1 ³ / ₁₆

All dimensions shown are in inches. The dimensions shown are approximate ones and certified diagrams should be used for installation purposes.

Silverson reserves the right to change dimensions and specifications without notice.

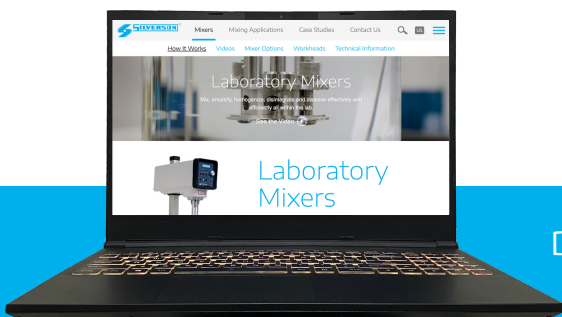

Discover our full range of high shear mixers at [Silverson.com](https://www.silverson.com) and revolutionize your mixing processes today